

STANDARD 1000 (500 + 500A)

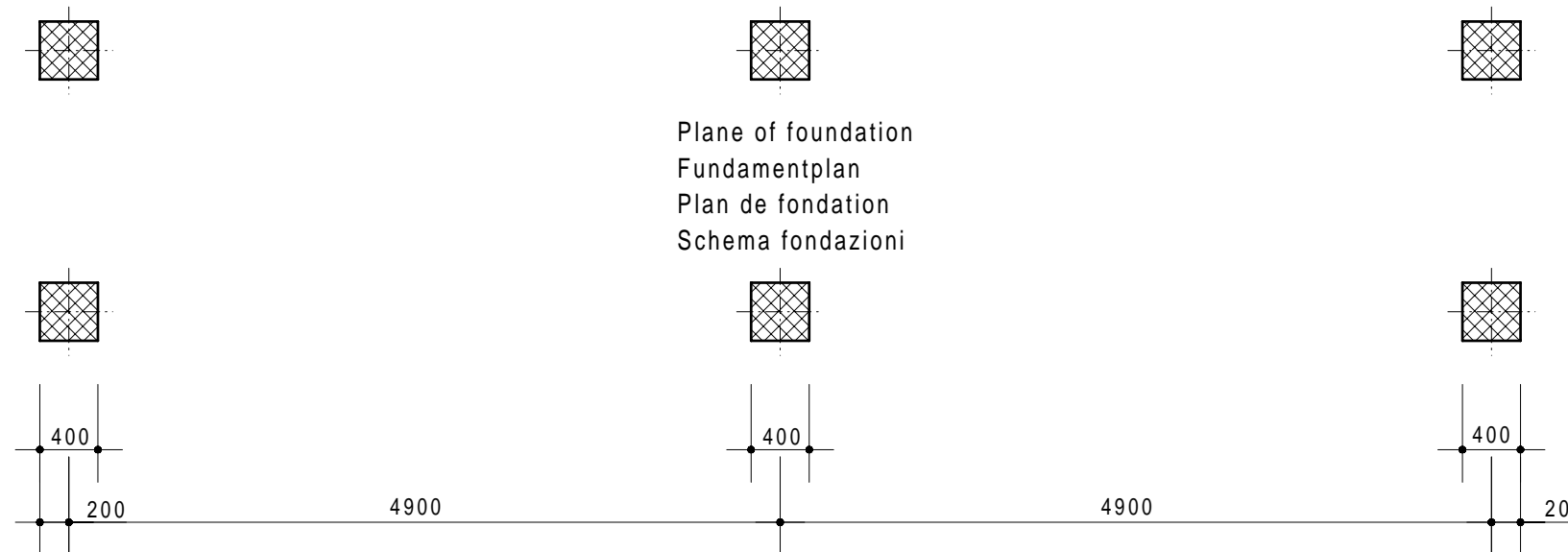

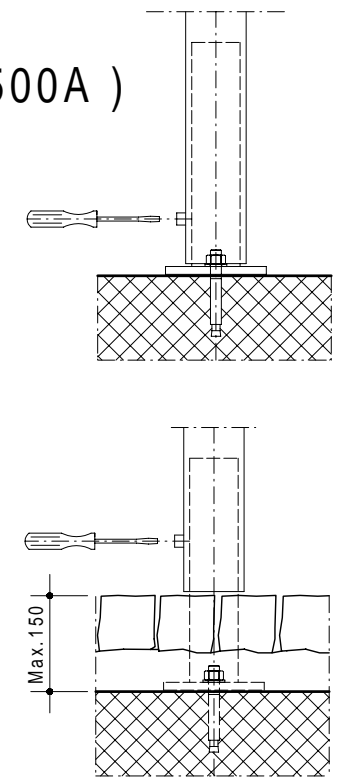
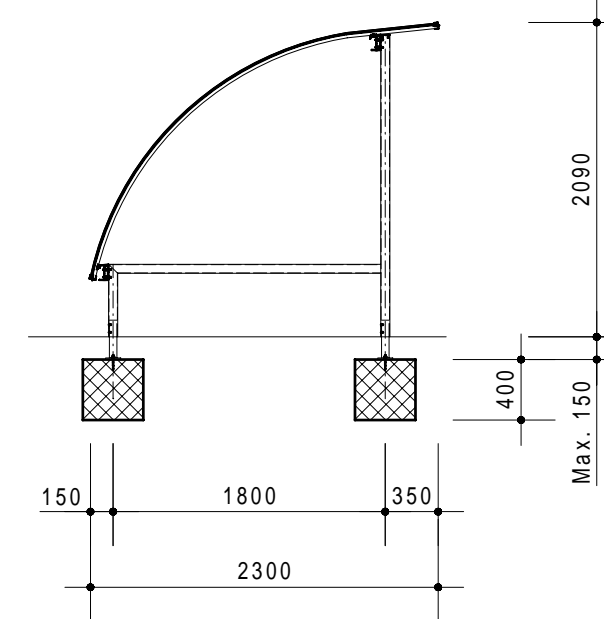

Plane of foundation
Fundamentplan
Plan de fondation
Schema fondazioni

ON REQUEST - AUS ANFRAGE - SUR DEMANDE - SU RICHIESTA

Wall side - Seitenwände
Finition laterales - Pareti laterali

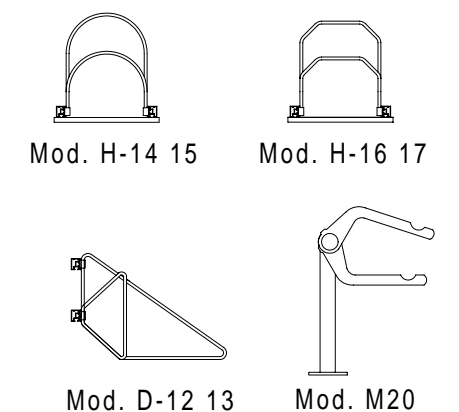
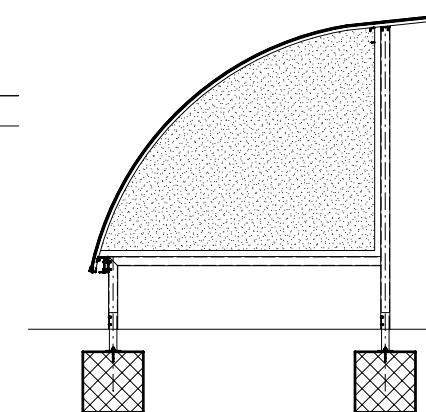
Holder - Velohalter
Support - Supporti



Trattamento: Ferro zincato a bagno		Alu ossidato naturale	N° pezzi
Committente:			N° ordine
Modello: STANDARD	Materiale: FERRO - STAHL		Data: Sett. 05
Descrizione COPERTURA CICLI E MOTOCICLI " STANDARD "			Disegnato: GB
ÜBERDACHUNGEN FAHRRADRÄDER UND MOTORRÄDER " Standard "			Scala: ---
 Weberrütistrasse 9 8833 Samstagern T 044 783 22 88 F 044 783 22 87 info@kernag.ch www.kernag.ch		N° dis. / Articolo	STANDARD 1000